

VIBRO/DYNAMICS

Wedge Isolators
Series 12W, 16W and 24W



Wedge Isolators

Vibro/Dynamics Wedge Isolators are designed for the free-standing installation of stamping presses, machine tools, plastic injection molding and die cast machinery.

The wedge design with its side adjust leveling screw makes them ideal for leveling and installing machines that cannot use vertical leveling screw type isolators because the mounting holes are too small or nonexistent.

Wedge Isolators are also available with our unique Glide/Ring™ damper designed to dissipate horizontal forces that cause some machines to walk. The Glide/Ring damper's built-in swivel automatically adjusts for an out-of-parallel condition between the foundation and bottom of the machine feet for improved machine support and isolator performance.



- ◆ **Quickly level and align machines with easy turning adjustment screw.**
- ◆ **Effectively isolate vibration with custom engineered elastomers.**
- ◆ **Uniformly support machinery with special swivel feature.**
- ◆ **Prevent walking with the unique Glide/Ring™ damper.**

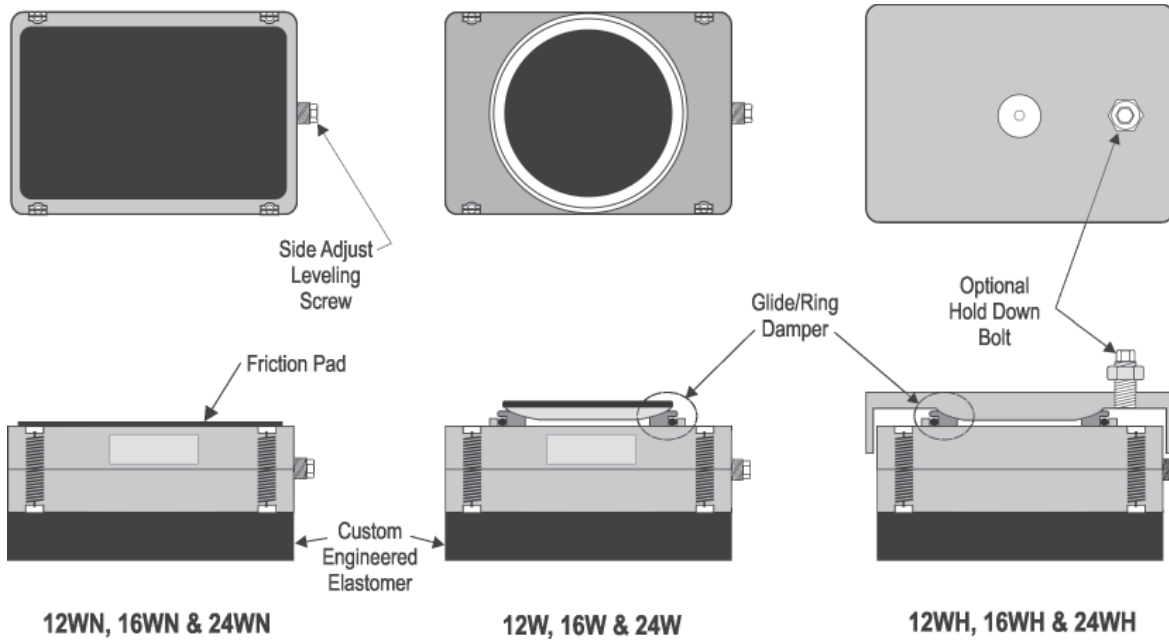

Vibro/Dynamics Wedge Isolators are available in three styles with static load ranges from 2,100 - 65,300 kg per isolator. Also available are versions with multiple layers of elastomers for added vibration and shock isolation.

Glide/Ring™ Damper

The *Glide/Ring Damper* is a unique device that provides uniform support and keeps machines from walking. It consists of a Swivel Dish, Swivel Seat, Damping Ring and Retainer Ring.

The *Glide/Ring Damper* has two functions. First, the Swivel Dish has a four degree tilt capability that automatically adjusts when the foundation and the bottom of the machine feet are not parallel. In an extreme out-of-parallel condition, one side of the isolator will compress more than the other, resulting in an uneven load pattern on both the machine's foot and the isolator's elastomer. The *Glide/Ring damper* provides uniform support for improved machine and isolator performance.

Second, the swivel seat is designed to move slightly in the horizontal direction, dissipating horizontal forces that cause some high-speed machines to walk.

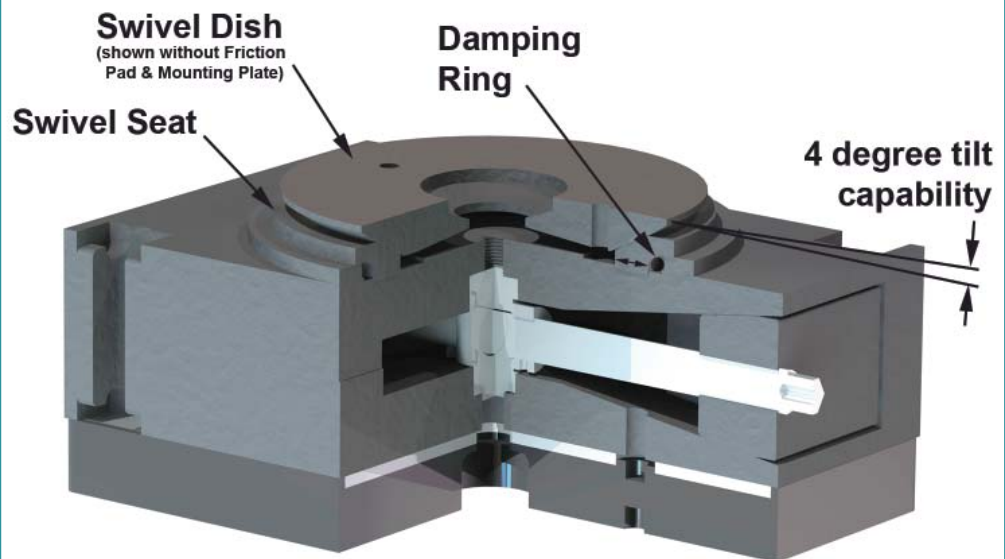

Technical Assistance

To assure the best installation, our application engineers will carefully analyze your particular application needs and recommend the proper isolator for the best installation. Please give us a call, and we will be happy to assist you in your selection.

VIBRO/DYNAMICS Corporation

2443 Braga Drive
Broadview, IL 60155-3941
E-Mail: vibro@vibrodynamics.com
Web site: www.vibrodynamics.com

Telephone 708-345-2050
Toll-Free in USA 1-800-842-7668
Fax 708-345-2225

Vibro/Dynamics is a registered trademark, and Glide/Ring is a trademark of Vibro/Dynamics Corporation.
©2002 Vibro/Dynamics Corp. All Rights Reserved.
Vibro/Dynamics Products are covered by one or more of the following U.S. Patents: 4,846,436; 4,930,741; 5,360,195; 5,577,703; 5,690,304; 5,738,330; and 6,116,565. Products are also protected by Foreign Patents. Other Patents Pending.